

## INDUCTIVE SENSOR FOR WEIGHING OF MASS

**Janusz Lewandowski**

MENSOR, Węglarska 50, 04-689 Warsaw (✉ [mentor@mentor.pl](mailto:mentor@mentor.pl), +48 22 613 08 74)

### Abstract

A new method measuring of mass in electronic system of scales has been described. The main element of this system is inductive measuring load cell, which was compared with strain gauge load cell. The aim of the paper is described advantages of the inductive measuring system of mass and explain some main problems of this system. Digital correction of the mechanical errors of the beam like: hysteresis, creep material of the beam under constant load, influence of ambient temperature was described.

Keywords: inductive load cell, electronic scales, measuring system of mass.

© 2011 Polish Academy of Sciences. All rights reserved

### 1. Introduction

Strain gauge load cells are commonly in use in the construction of electronic weighing machines and weighing modules. Mass production of such elements led to the achievement of their high technological level and low production costs – the development of new constructions and technologies in this field is a particularly difficult task [1, 2].

The development of a new operating principle and use of new physical phenomena seems to be the only way for technological progress in the field of mass weighing. A strain gauge load cell consists of two elements: a springy beam, most often made from an aluminium alloy of stainless steel, as well as tensiometric sensors [3, 4, 5].

The concept of a springy beam as the measuring element to which an external measured force is applied, is right, because it constitutes a stable, repeatable mechanical unit resistant to overload [3]. Doubts appear as to strain gauges which are bonded to the beam and measure strains on its surface at its thinnest cross-section.

A film strain gauge subjected to tensile forces is a measuring element not resistant to outside forces mainly due to the fact that it is joined with the beam by glue, which together with the outer regions of the beam is being stretched or compressed. Moreover, the glue layer situated between the beam and the strain gauge is influencing the static characteristics of the whole measuring system; this effect can be neglected at higher measuring ranges, e.g. up to several kilograms, while at the lower measuring ranges the influence of glue stiffness is noticeable. Thus, a practical limit of using strain gauges is the range 0 – 200 g, in the majority of applications the range from 0 to 2 kg – electronic scales for lower loads are built with magnetoelectric transducers.

Taking advantage of the fact that the elastic properties of good aluminium and stainless steel alloys allow to design force transducers which use the principle of measurement of these properties, in the research presented here it is assumed that this principle is invariant, i.e. it is assumed that a force  $F$  applied to the end of the measuring beam is measured through measurement of its deflection  $x$ :

$$F = f(x), \quad (1)$$

where:  $F$  – is the force to be measured,  $x$  – the displacement at the end of the beam.

The measurement of displacement  $x$  by means of strain gauges has been abandoned and they were replaced by inductive sensors [6, 7, 8]. The inductive displacement sensor is a commonly known good sensor for measuring small displacements  $x$ .

The operating principle is exceptionally simple – unfortunately its realization presents many technological and design problems. The main problems include the influence of ambient temperature on the windings of the inductive displacement sensor, which in this case forms a resistive temperature sensor. Similarly, the ambient temperature changes the value of Young's modulus of the aluminium alloy, from which the measuring beam is made. This influences significantly its elasticity.

Another problem is here the distribution of the magnetic field existing around the inductive displacement sensor; this field differs in air cracks and in the aluminium alloy, in the latter case forming eddy currents. Besides, the distribution of the magnetic field can be disturbed by insertion of a metal object in its region, e.g. by putting a standard weight on the scale pan.

Attainment of high resolution of the inductive displacement sensor and of its linear static characteristics is a serious design problem. For this reason it is not possible to employ commercial inductive displacement sensors for this purpose.

Basic design problems with the inductive measuring load cell are connected with situating the openings and channels in its interior – this is linked with choosing an optimal machining process and thermal processing of the aluminium alloy.

This paper discusses the above problems. Work has been carried out systematically for several years by various institutes and technical universities, under the direction of the MENSOR company. It should be stressed that the results of individual research steps were tested in short production series of electronic scales [9] and opinions were given by their users. This process was repeated many times and ensured a constantly improved design level of the inductive load cells. Without linking the production processes with research, achievement of results described in this paper would not have been possible.

## 2. State of the mass-measurement technique

In measuring mass, two basic measuring systems are commonly in use:

1. A system based on compensation in an equilibrium of forces system, measuring mass by means of an electromagnetic servo-motor (Fig. 1). The weighed mass is here proportional to the current flowing through the coil:

$$mg = ki, \quad (2)$$

where:  $m$  – the measured mass,  $g$  – acceleration of gravity,  $k$  – proportionality factor,  $i$  – current flowing through the coil winding.

Thus: 
$$m = \frac{k}{g} \cdot i. \quad (3)$$

In a practical solution of mass measurement (Fig. 1) the force  $mg$  is applied through a system of weighbeams of different leverage dependent upon the range of the measured mass. In the case of upper-pan scales it is necessary to use a lever system compensating the non-axial load on the pan by the measured mass. The described measuring system is commonly used for accurate measurement of mass and at low measurement ranges, e.g. in analytical balances.

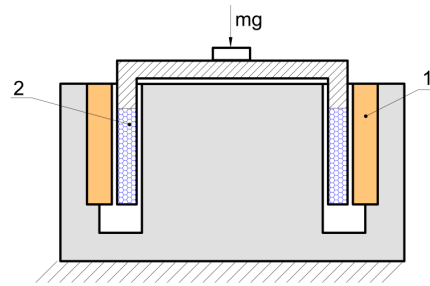

Fig. 1. Functional diagram of a mass-measuring system with an electromagnetic servo-motor; 1- permanent magnet, 2 – coil suspended on a system of beams (not shown in this picture)

The electromagnetic system described above has, however, several disadvantages, including:

- a complicated precision mechanical construction of the beam system and the compensating mechanism of the non-axial load
- relatively large own mass resulting from the size of the permanent magnet (Fig. 1)
- small immunity to external varying magnetic fields
- considerable energy consumption (current  $i$  in equation (3)), accompanied by heat radiation and temperature change inside the scale
- small resistance to shocks, acceleration and vibrations.

These disadvantages were the reason of searching for other design solutions without the aforementioned flaws.

2. In the sixties a new design solution came into existence – it was based on the measurement of the elastic strain of a special profile made from an aluminium alloy or steel (Fig. 2).

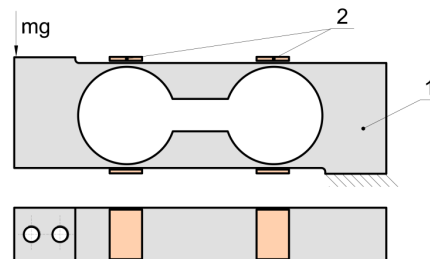

Fig. 2. Strain gauge load cell; 1 – body of the beam; 2 – strain gauges.

Four strain gauges glued at places of smallest cross-section change their resistance in the effect of acting with a force  $mg$  on the beam. The strain gauges are connected in a Wheatstone bridge circuit whose output voltage  $U$  is proportional to the measured mass  $m$ ,

$$U = k_1 \cdot m, \quad (4)$$

where:  $U$  – voltage across the diagonal of the bridge,  $k_1$  – proportionality coefficient,  $m$  – the measured mass.

The solution described above introduced a significant progress into mass measurement techniques; it is simple and more reliable than the system based on a magnetoelectric servo-motor - measurement of large mass is possible with small power consumption. This solution found widespread use in the construction of electronic scales, mainly for loads above two kilograms and with a resolution not exceeding 6000 graduations.

The strain gauge measurement beam has, however, many disadvantages (Fig. 2):

- small resistance against vertical and lateral overloads (150 %)

- range of measurement limited to above 2 kg (strain gauge scales are produced also with weighing capacities below 2 kg, but they are of smaller accuracy and they do not meet the requirements of the PN-EN 45501 standard)
- limited measurement accuracy ( in general, class III accuracy)
- complicated technology of gluing the strain gauges
- necessity of compensating the change of Young's module of the metal beam as a function of temperature , by proper choice of strain gauge sensors.

In spite of the disadvantages mentioned above , strain gauge load cells found common application, besides the arrangement of Fig. 1, and many designers cannot imagine the construction of scales without these measurement arrangements.

### 3. Inductive measurement load cell

A new design solution uses other physical effects than those described before. The strain gauges, by their construction designed for measuring local strains in metal structures, have been abandoned and in their place a new sensor has been used, known from other areas of metrology – the inductive displacement sensor (Fig. 3).

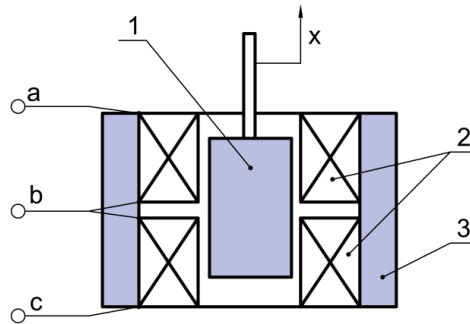

Fig. 3. Schematic illustration of an inductive displacement sensor: 1 – ferrite core, 2 – coils, 3 – ferrite pot, a, b, c – output terminals from the coils.

The sensor consists of two coils with opposite winding sense, a moving core and a ferrite pot which closes the changing magnetic field flux originated by the current flowing through the coils. The sensor operates in a differential circuit, i.e. the central symmetric position of the core with respect to the coils the output voltage of the measuring circuit (Fig. 4) is equal zero. A movement of the core from this equilibrium position causes the appearance of voltage  $U$  proportional to the displacement  $x$  of the ferrite core.

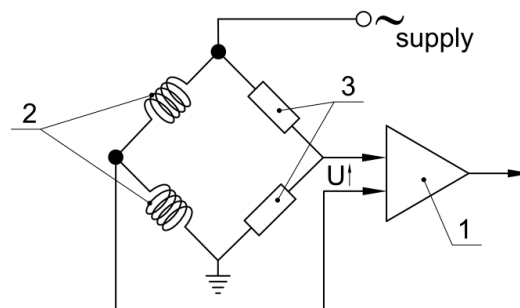

Fig. 4. Schematic diagram of the measurement bridge with an inductive sensor, 1 – ac current amplifier, 2 – coils, 3 – resistors,  $U$  – bridge output voltage.

The inductive displacement sensor described above has been used in the construction of an inductive load cell (Fig. 5). The movable part of the beam is connected with the scale pan on which the measured mass is being placed. In the result of applying this mass a small of flat springs occurs together with movement of the core of the inductive displacement sensor. The core of the sensor is connected with movable part, while the body of the inductive displacement sensor with the fixed part of the measurement beam.

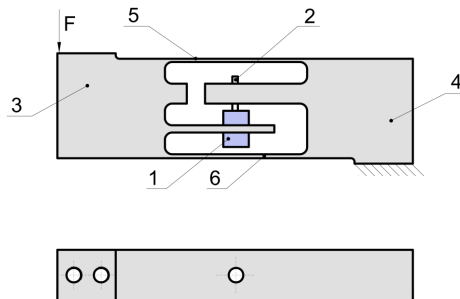

Fig. 5. Inductive measurement beam, 1- inductive displacement sensor, 2 – sensor core, 3 – movable part of the beam, 4 – fixed part of the beam, 5,6 – measuring springs.

Measuring elements of the inductive load cell are two flat springs parallel to each other, on their one side fastened to the fixed part of the beam, on the other side to the movable part. These connections are stable, as the springs are made from the same material as the fixed and movable parts, by machining.

#### 4. Comparison of the strain gauge load cell with inductive one.

There are the following differences between the strain gauge load cell (Fig. 6b) and the inductive load cell (Fig. 6a) :

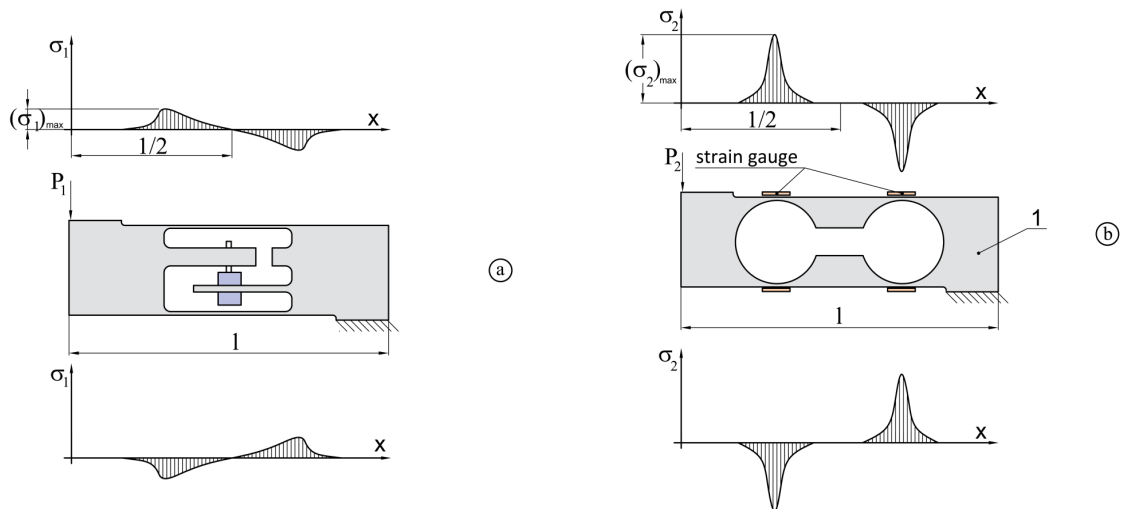

Fig. 6. Distribution of stresses in the inductive load cell (a) and the strain gauge cell (b).

1. The measurement of the displacement of the inductive measuring beam is touchless – the elastic system is not burdened with the stiffness of strain gauges and glue
2. The inductive sensor measures the total resulting deflection of the measuring beam and the strain gauges measure the elastic strains in specific places of the beam. In a strain gauge beam it is necessary, for technological and production reasons, to concentrate stresses in places where the strain gauges are glued. The section (Fig. 6) in which the greatest surface

deflection occurs, must be greater than the active length of the strain gauge, so that it can be glued to this surface in a reproducible way.

Local concentration of stresses brings their value to those allowable for this kind of material. This increases hysteresis and leads to the effect of material “flow” under constant load.

3. The core of the inductive displacement sensor can move freely even by 1 mm, which allows in scales with small weighing capacity to achieve a 10-fold overload capacity. This is of particular importance in industrial applications of electronic scales built on the principle of the inductive measuring beam.

4. An inductive measuring beam may have low measuring ranges, e.g. 0 – 30 g, unattainable in strain gauge beams. Here the construction of laboratory scales with class-II accuracy is possible, heretofore possible only with magnetolectric servo motors.

5. The inductive method of mass measurement put no limits on high measuring ranges, of the order of tens of tons. The measurement of the total displacement of the measuring beam with an inductive sensor, in contrast to the measurement of local stresses by means of strain gauges, leads to more simple design solutions, e.g. the measurement of elongation of a metal rod stretched by two axially applied forces is a simple example of application of the inductive method to large measurement ranges.

6. The accuracy of the inductive measuring beam is higher than that of a strain gauge beam, which results from the distribution of stresses in both beams (Fig. 6). Smaller stresses in measuring springs of the inductive sensor assure a smaller hysteresis, smaller flow of material under constant load and greater linearity of the static characteristics.

Assuming equal load of the strain gauge beam and the inductive beam (Fig. 6) with forces  $P_1$  and  $P_2$ , i.e.:

$$P_1 = P_2, \quad (5)$$

where:  $P_1$  – the force applied to the inductive beam,  $P_2$  – the force applied to the strain gauge beam, and assuming equal deflections of both beams  $f_1$  and  $f_2$ :

$$f_1 = f_2,$$

where:  $f_1$  - is the deflection of the inductive beam,  $f_2$  - the deflection of the strain gauge beam.

From the Castigliani theorem defining the internal elastic strain energy  $V$  of both beams produced in the result of applying external forces  $P_1$  and  $P_2$  we obtain:

$$\frac{\partial V_1}{\partial P_1} = f_1 \quad \frac{\partial V_2}{\partial P_2} = f_2 \quad (6)$$

From the above equations we see that the internal elastic strain energies of both systems are equal, thus the areas under the curves should be the same

$$\int_0^{l/2} \sigma_1 dx = \int_0^{l/2} \sigma_2 dx \quad (7)$$

thus, taking into account the character of curves  $\sigma_1(x)$  and  $\sigma_2(x)$ , the maximal stresses in the strain gauge beam  $(\sigma_2)_{\max}$  are considerably greater than the maximal stresses in the inductive beam  $(\sigma_1)_{\max}$  under the assumption of equal external conditions and the same material from which both beams are fabricated

$$(\sigma_1)_{\max} < (\sigma_2)_{\max} \quad (8)$$

Thus, making two beams; a strain gauge beam and one inductive, from the same material, the hysteresis errors and material flow will be smaller in the first one.

Calculation of the static characteristics of the inductive beam is relatively simple, the deflection  $f_1$  can be determined from the equation well-known in strength of materials science:

$$f_1 = \frac{l^3 P_1}{bh^3 E}, \quad (9)$$

where:  $l$  – length of spring,  $P_1$  – the force,  $b$  – width of springs,  $h$  – thickness of springs,  $E$  – Young module.

## 5. Digital correction of the mechanical errors of the beam

The main research work on the inductive load cell relates to improve its metrological properties in a mechanical way, i.e. choice of the optimal geometry, the use of appropriate materials, optimization of technology of production etc. A mechanical element which has good metrological properties is more reliable and cheaper in production than a measurement system, additionally equipped with an electronic circuit.

Unfortunately, there is a limit to enhancement of metrological properties of the inductive load cell through its mechanics – only the employment of digital techniques is left to the designer. The real value of the output signal of the measurement load cell is then fed to a processor memory and subsequently corrected by a mathematical equation appropriate for the given type of errors. The elaboration of an error correction algorithm and design of an appropriate equation is the first important step of the programming process.

Before discussing the aforementioned methods of digital correction of mechanical errors, an analysis of physical effects which cause these errors ought to be carried out.

### 5.1. Hysteresis

The inductive method of measuring mass is based on the measurement of deflection of an elastic beam which, as every elastic element, is characterized by hysteresis. The value of this hysteresis is very small for beams made of aluminium alloy PA6 or PA7 and on the average is 3 to 5 graduations at a resolution of 30 000. The Table 1 shows the results of hysteresis research of a beam with a 15 kg weighing capacity (the hysteresis test used an electronic measurement system with a resolution of 100 000 by means of which it was established that hysteresis errors of the electronic system with a resolution of 30 000 used in the construction of electronic scales are negligibly small in comparison with analogous mechanical errors of the inductive load cell).

Table 1. Results of hysteresis of an inductive load cell with 15 kg weighing capacity (shown in Fig. 7).

m [kg]	indication [kg] (growing)	indication [kg] (diminishing)
0,05	0,0495	0,0500
0,5	0,4995	0,5005
2	1,9995	2,0010
5	4,9995	5,0010
10	10,0000	10,0005
15	14,9990	14,9990

The above table shows the values of mass  $m$  which was loading the load cell in function of indications of the display on the weighing assembly, for growing and diminishing values of  $m$ :

$$m = f(w), \quad (10)$$

where:  $m$  – the mass which loaded the measuring beam,  $w$  – display indication.

The above results can be presented in the form of a graph, where on the ordinate axis the difference between real and the theoretical line with inclination  $\text{tg } \alpha$  determined by connecting the origin of coordinates with the point lying at a distance of  $\frac{3}{4}$  from this origin, Fig. 7.

Because of the small values of hysteresis errors of the inductive load cell, a 1000-fold magnification has been employed on the x-axis of Fig. 7 in order to illustrate a typical hysteresis curve. The small values of hysteresis errors characterizing aluminium alloys of PA6 type are their advantageous feature in the construction of measurement systems.

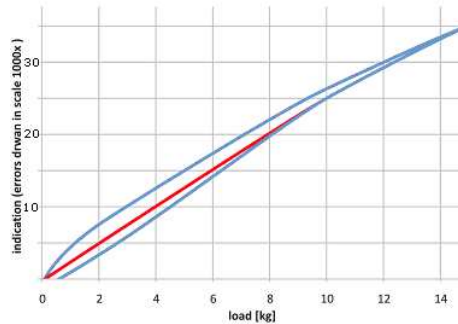

Fig. 7. Illustration of errors of an inductive beam with 15 kg weighing capacity.

The choice of  $\frac{3}{4}$  Max on the x-axis for the second point through which the theoretical line has been drawn (Fig. 7) is dictated by good linearity at this point of the real static characteristics of the inductive load cell – in the maximum point of this characteristics the line shows a curvature resulting from the properties of the inductive displacement sensor.

The value of hysteresis of an inductive load cell depends on two parameters:

- the geometry of measuring springs
- the kind of material the beam is made from.

According to Section 4.1 a small hysteresis is shown by beams having flat measuring springs. Their fabrication in a similar way as in strain gauge beams, i.e. in the form of holes situated in the vicinity of external surfaces of the beam (Fig. 8), causes hysteresis errors allowable for class-III scales.

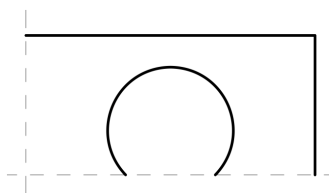

Fig. 8. Circular form of the measuring spring.

The technology of fabrication of the measuring spring shown in Fig. 8 is of course simpler than from the technology leading to a flat spring. In spite of a similar shape in this case of the measuring spring in an inductive load cell and in a strain gauge load cell, the operating principle of both load cells and working conditions of both springs are different. In the case of the strain gauge load cell we measure the intensity of stress on the surface of the narrowest cross-section, while on the other hand in the inductive load cell we measure the summary total deflection of four springs.

An additional factor influencing the value of the discussed hysteresis is the machining process used in the fabrication of an inductive load cell. During this machining process heat is



produced which has an effect on the change of the crystalline structure of the material layer near the cutting tool, thereby impairing its elastic properties.

The total effect of this phenomenon is the greater the thinner the measuring spring, because the material layer impaired due to machining has a greater percentage of thickness of the whole spring. On the other hand, in thinner springs considerably smaller stresses occur than those allowable for the given material. Both these superimposed effects cause that in practical designs of inductive load cells the smallest hysteresis appears for measurement ranges near 0 – 15 kg (Fig. 9).

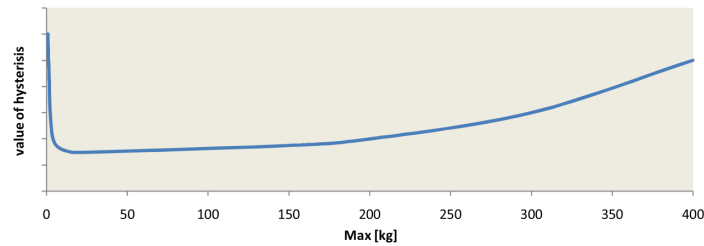

Fig. 9. Hysteresis values of an inductive load cell in function of measuring range –as the result of machining and stresses occurring in the measuring springs.

### 5.2. Creep material of the beam under constant load

The phenomenon of material creep under constant load is a commonly known in material science – it occurs also in the case of the inductive measuring beam. Similarly as in hysteresis, the slow increase of deflection of the inductive beam loaded with a constant force depends on:

- the type of material,
- beam geometry

The deflection characteristics of the beam as a function of time, under the influence of an applied constant load is shown in Fig. 10 (red line).

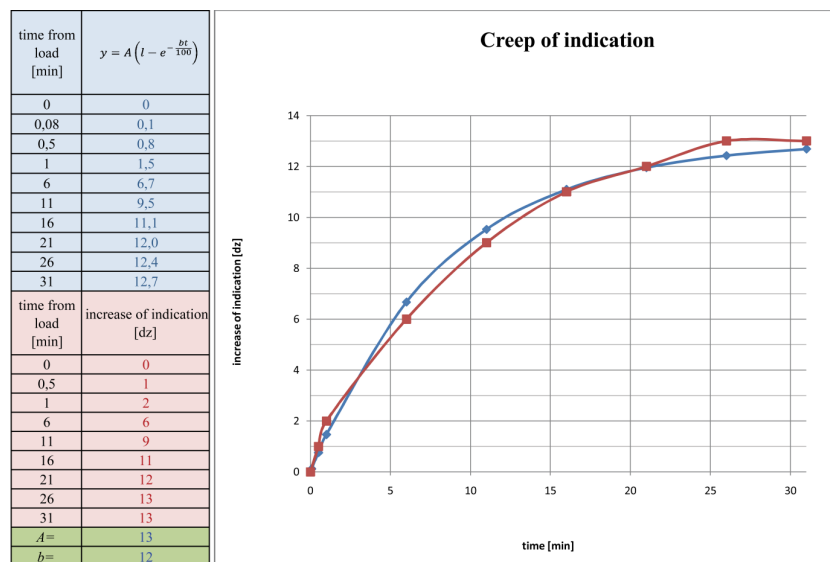

Fig. 10. Characteristics of an inductive measuring beam loaded with a m=15 kg mass

It can be seen in Fig. 10 that in the first minutes after application of load the strains of the beam are relatively fast – later these strains diminish – approximately according to an exponential curve:

$$y = A(1 - e^{-\frac{bt}{100}}), \quad (11)$$

where:  $y$  – beam deflection,  $A$  and  $b$  – coefficients,  $t$  – time.

Fig. 10 shows an exponential curve (blue) determined from the last equation, choosing coefficients  $A$ ,  $b$  such that both curves coincide.

In some cases a better approximation of the creep characteristics is obtained by using two terms of an exponential function, as the initial deformation of the beam after loading it with a mass is relatively fast and later asymptotically approaches a constant value

$$y = A_1(1 - e^{-\frac{b_1 t}{100}}) + A_2(1 - e^{-\frac{b_2 t}{100}}), \quad (12)$$

where:  $y$  – beam deflection,  $t$  – time,  $A_1$ ,  $A_2$ ,  $b_1$ ,  $b_2$  – coefficients characteristic for a given type of material.

In order to introduce into the scale program a correction of the creep effect for the inductive measuring beam, coefficients  $A_1$ ,  $A_2$ ,  $b_1$ ,  $b_2$  should be determined experimentally.

The effects of hysteresis and creep are closely linked with each other; the hysteresis loop visible in Fig. 7 is due to material creep for individual measurement points. Thus the values of indications lying on the lower curve are smaller than those lying on the theoretical straight line.

## 6. Influence of ambient temperature

A change of the ambient temperature influences Young's module of the aluminium alloy of which the inductive load cell is made – this causes a change of slope of the static characteristics (amplification change) and a shift of the initial operating point. The equation of this characteristic, i.e. of a straight line in the  $(w, m)$  coordinate system has the form:

$$w = a \cdot m + c, \quad (13)$$

where:  $w$  – indication of measuring system,  $m$  – the weighing mass,  $a$ ,  $c$  – coefficients.

$$a = f_1(T) \quad c = f_2(T) \quad (14)$$

where:  $T$  – is the environmental temperature.

Coefficient  $a$  determines the amplification (gain) of the measuring system, while coefficient  $c$  characterizes the shift of the discussed characteristics on the  $(w, m)$  plane.

Fig. 11 presents two static characteristics: 1 – before the temperature compensation (red), determined after assembly of the scale, and 2 (blue)- after temperature compensation i.e. after a change of the coefficient compensating the amplification change  $a$  and a change of coefficient  $c$  compensating the operating point shift.

The temperature compensation is carried out by drawing straight line 2 through two points for a zero load and a load equal to the calibrating mass (Fig. 11).

During normal scale operation the ambient temperature is measured by a temperature sensor with a resolution of  $\frac{1}{4}$  °C and the change of Young's module of the inductive beam corrected by means of a microcontroller. The temperature sensor is placed in the body of the beam to preserve the same measurement dynamics as the measuring beam.

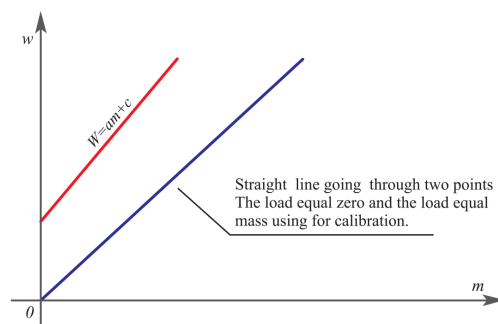

Fig. 11. Effect of ambient temperature on the static characteristics of the inductive sensor and temperature compensation.

## 7. Summary

Minimization of the abovementioned indication errors of the inductive load cell occurs in two stages;

- the first stage consists in design and development work carried out in parallel with a serial production, for example the effect of hysteresis and creep can be obtained through choice of the material the beam is made of, and by appropriate thermal processing,
- the second stage includes the correction of mechanical errors of the beam by digital methods by means of an appropriately programmed microcontroller.

From the reliability point of view of scale operation it is better to use a measuring beam which would not require an additional digital compensation – this can be achieved for class-III scales. In the case of class-II scales a digital compensation of the abovementioned indication errors is necessary, particularly minimization of the hysteresis effect, material creep under constant load and nonlinearity of static characteristics.

A common construction of inductive load cells for all measurement ranges allows to use one microprocessor type and one program for all designs. This is possible thanks to identical errors: of hysteresis, creep, linearity of static characteristics, influence of ambient temperature and humidity for measurement ranges from 20 kg to 400 kg.

This results from the fact that all load cells are made of the same material. Equipped with the same inductive displacement sensor and operate with the same deflection of 0.2 mm. Thus, for example, the effect of ambient temperature on the change in Young's module for the aluminium alloy the measurement beams are made of, is identical for all designs.

The research results presented in this paper were used in the production of inductive load cells by MENSOR Company and electronic scales build with the use of the described load cells have received the WE certificate in compliance with EU Standard PN-EN 45501, No. PL 06 003 issued by the Main Measurement Office in Warsaw.

## References

- [1] Jafariapanach, M., Al-Hashimi, B.M., White, N.M. (2003). Load Cell Response Correction using Analog Adaptive Techniques. *IEEE International Symposium on Circuits and Systems*. Bangkok. Tailand, IV752-IV755.
- [2] Jafariapanach, M., Al-Hashimi, B.M., White, N.M. (2005). Dynamic Sensor Compensation Using Analogue Adaptive Filter Compatible with Digital Technology. *Circuits, Devices and Systems. IEE Proceedings*, 745-751.
- [3] TECH NOT Measurements Group – Fatigue Characteristics of Micro-Measurements Strain Gages, Measurements Group. Inc. P.O. Box 27777. Raleigh. North Carolina. USA.

- [4] TECH NOT Measurements Group – Noise Control in Gage Measurements. Measurements Group. Inc. P.O. Box 27777. Raleigh. North Carolina. USA.
- [5] TECH NOT Measurements Group – Errors Due to Transverse Sensitivity in Strain Gages. Measurements Group. Inc. P.O. Box 27777. Raleigh. North Carolina. USA.
- [6] Lewandowski, J. *Measuring Transmitter of Electronic Scales*. Patent, no. PL 175320 B1.
- [7] Lewandowski, J. (2000). Inductive Method for Measure of Mass. *PAR*, 5. (in Polish)
- [8] Lewandowski, J. (1999). Inductive Sensors of Force. *Proceedings of the 4<sup>th</sup> International Seminar in Precision and Electronic Technology*. INSEL. Warsaw, 4, 225-231.
- [9] Lewandowski, J. (2007). Computing Measuring System of Mass and Non-electric Physical Parameters. *Proceedings of the 3<sup>th</sup> International Seminar in Precision and Electronic Technology*. INSEL Warsaw, 3, 187-190.