

MEASUREMENT SYSTEM FOR DETERMINATION OF SUPERCAPACITOR EQUIVALENT PARAMETERS

Ryszard Kopka, Wiesław Tarczyński

Opole University of Technology, Department of Electrical, Control and Computer Engineering, Institute of Control and Computer Engineering, Sosnkowskiego 31, 45-272 Opole, Poland (✉ r.kopka@po.opole.pl, +48 77 449 8652)

Abstract

In this paper a measurement system for determination of supercapacitor equivalent parameters is proposed. Specific properties of materials used for supercapacitor construction require some advanced tools and measurement procedures to be applied during tests. The measurement system allows to measure values of equivalent parameters by both the DC and AC method whilst keeping appropriate time criteria required by this type of devices. Furthermore, in this paper the most relevant properties and measurement capabilities of the proposed system are described as well as some exemplary values of the supercapacitor equivalent parameters measured experimentally are presented.

Keywords: supercapacitor, measurement system, equivalent series resistance, equivalent capacitance.

© 2013 Polish Academy of Sciences. All rights reserved

1. Introduction

Special properties of supercapacitors result in gradual growth of their use in various applications. The very first applications were associated with maintaining the power of semiconductor memory of microprocessors devices. Nowadays supercapacitors more often are used in power systems, together with batteries or accumulators. Large capacitance allows generating a small value current for a long period time or alternatively to provide high value current for a short period. Fast charging technology allows using the supercapacitors in energy recovery systems, for example during a braking process in kinetic energy recovery systems that may be used in various kind of vehicles. The main advantages of supercapacitors is their large capacitance, high power density, extremely long life-time, large number of charge and discharge cycles and practically maintenance-free operation [1, 2].

As mentioned before, today supercapacitors are used in many application domains, including supply systems for memory circuits, in start up systems for combustion engines for the purpose of reducing the battery size or in backup power systems e.g. in airplanes. In all these applications, the requirement of high reliability and full working order is of highest importance. However, despite their very high reliability, ageing processes and reactions taking places inside the supercapacitors during their operation lead to degradation of their properties. Mostly this can be observed as decreased capacitance and increased internal series resistance. These processes are dependent on many factors such as stability of the operating voltage, temperature and current values and the number of charging and discharging cycles. Therefore, it is very important to perform possibly accurate measurements of all these parameters, both before and during the operation or servicing time in order to precisely define their health [3].

The wide range of nominal capacitance values ranging from fractions of F to several thousand F, and equivalent series resistance ranging from m Ω to tens of Ω as well as the

specific properties of the materials the supercapacitors are made of, require using very specific measurement systems and procedures to carry out the tests.

This paper presents the properties of a developed testing system which allows measuring basic parameters of supercapacitors as well as conducting accelerated ageing tests. The system allows carrying out tests for charge and discharge cycles using either voltage or current sources with different intensity and for different time parameters of the cycle. This allows generating sine waves with different amplitude and DC offset, too. Research can also be carried out for various ambient temperatures of a supercapacitor by placing it in a special temperature chamber. All tests are carried out according to prepared algorithms and are generated by a PC equipped with a data acquisition card, whilst the measurement results are stored on a hard disc.

The article is divided into the following sections. In Chapter 2 the structure and properties of supercapacitors and the methods of measure their basic parameters are described. Part 3 contains information on the degrading processes or failure mechanisms and the methods to observe them. Chapter 4 describes in detail both test setup and test procedures. Results obtained during the tests are shown and described in Section 5. Finally, concluding remarks comprise the last part of this work.

2. Supercapacitor construction

Specific properties of the supercapacitors result from properties of the materials they are built of. Supercapacitor electrodes are made of aluminum tape coated with activated carbon and separated by a thin layer of a separator. Activated carbon, mainly in the form of carbon nanotubes, has a very large active surface area, it excess of several thousand square meters per 1 gram of carbon. Both electrodes are electrically isolated by a thin porous membrane called a separator made from plastic. The separator is not a dielectric, as in typical capacitors, it only prevents a short circuit of the electrodes. The electrodes and the separator are impregnated with an organic electrolyte. The surface of contact between the conductive electrodes and the electrolyte is treated as a dielectric and ions which are accumulated on the whole surface are a very short distance away. The insulating layer prevents the flow of charge to the electrodes. The boundary value of the voltage which such a layer can withstand is known as the decomposition voltage. Exceeding it leads to penetration of the electrolyte and the electrode. The value of this voltage depends mainly on the temperature of the supercapacitor.

Although the supercapacitors belong to the group of electrochemical elements, there are no chemical reactions/processes whatsoever involved in the process of charge collection. The charges are collected only by the polarity of the electrolyte which guarantees reversibility of the charge / discharge process [4, 5].

The physical model of a supercapacitor may be very similar to the typical capacitor types, e.g. electrolytic capacitors. Besides the capacitance between the electrodes it includes also inductance and serial and/or parallel resistance. A simplified equivalent model is presented in Fig. 1. It contains parasitic inductance L , mainly depending on the leads and the shape and dimensions of the supercapacitor, series resistance R_s representing the conduction resistance for electrons and ions, whilst parallel R_p represents the leakage current between the electrodes.

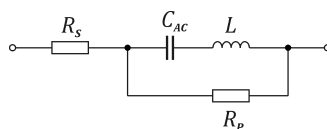

Fig. 1. Simplified equivalent circuit of a supercapacitor.

Although there are a lot of similarities between a supercapacitor and the typical electrolytic capacitor, these two elements differ significantly from each other. This is not only because of the difference between their capacitance, but the difference also lies in their behavior in relation to both constant and variable signals, as shown in Fig. 2. These differences make it necessary to carry out the measurements of their performance in different ways.

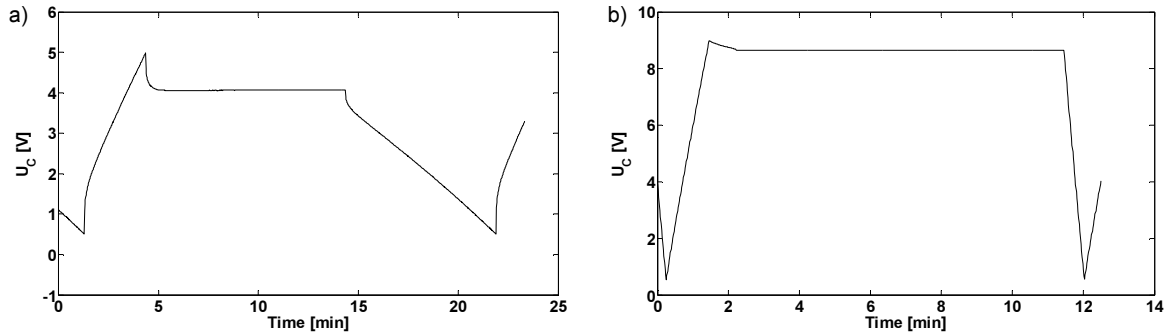

Fig. 2. Charge/discharge cycle of two kinds of capacitors:
 a) 1 F supercapacitor, b) 3300 μF typical electrolytic capacitor.

The model shown in Fig.1 is a simplified first-order model of a supercapacitor. In fact, mainly due to the properties of the porous material the electrodes are made of, a much more suitable model for a double-layer capacitor is the distributed model, as shown in Fig. 3. Such a structure of the model is the result of the very large electrode surface which affects the ions so that they require a long time to reach all places on the electrode.

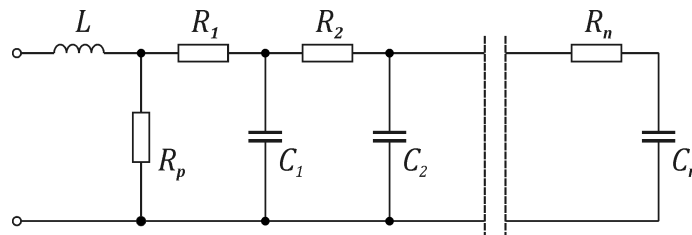

Fig. 3. Distributed elements model of a supercapacitor.

The properties of the supercapacitor are described by two parameters: equivalent series resistance ESR and equivalent capacitance C . The equivalent series resistance is a combination of parallel R_p and series R_s resistances and is associated with loss of energy inside the supercapacitor changing its internal temperature. In the case of using of supercapacitors for maintaining a semiconductor memory, its value is not critical due to the small current. However, in energy supply systems, the value of this resistance must be absolutely as small as possible, to reduce the voltage drop during the flow of a large current. The differences of properties of the supercapacitors for various applications are clearly visible on their charge/ discharge cycle characteristics as shown in Fig. 4.

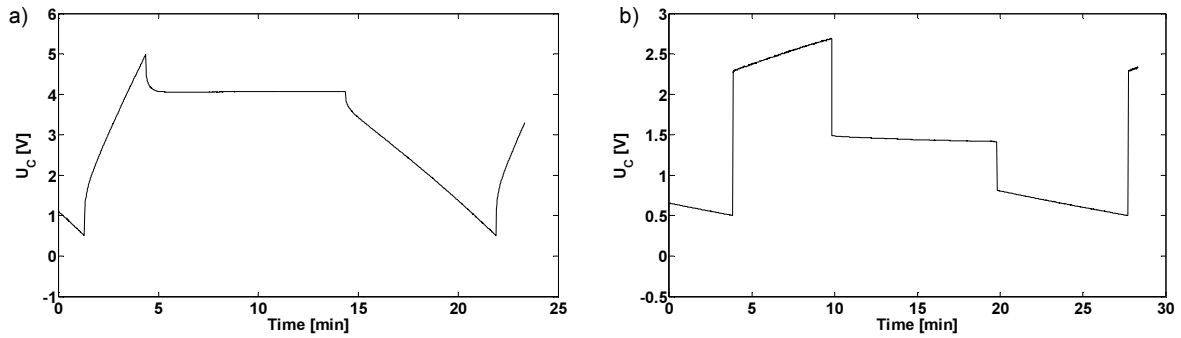

Fig. 4. The charge/discharge cycle of supercapacitors:
a) 1 F capacitance and 5.5 V nominal voltage, b) 100 F capacitance and 2.7 V nominal voltage.

3. Failure mechanisms in a supercapacitor

The properties of supercapacitors change during their operation due to changes of their parameters. Degradation processes can be observed by controlling the values of capacitance and equivalent series resistance. Loss of capacitance is related to decrease of the active surface of the carbon electrodes thus leading to a decrease of the amount of ions in the electrolyte. The speed of this process depends on the operating temperature, the number of charge and discharge cycles as well as on the operating voltage. A growing number of charge/discharge cycles makes the adhesion processes at the collector electrodes weaker, which also reduces the number of available ions thus increasing the equivalent series resistance. It is assumed that a 20% decrease of the capacitance C and 100% increase of the series resistance ESR means that the supercapacitor is damaged [6, 7].

4. Setup and measurement procedures

Complex electrochemical processes and high reliability requirements make it necessary to use specialized measuring systems and advanced measurement methods. In order to assess their parameters the measurements are carried out both during the manufacturing process as well as during normal operation. The values obtained depend on the measurement methods and the way the supercapacitor is prepared. Due to phenomena occurring inside the supercapacitors it is necessary to carry out the measurements keeping sufficient time gaps and during a long period of time so that the supercapacitor could reach its steady state.

4.1. Measurement procedures

The values of equivalent parameters of a supercapacitor can be measured using DC and AC methods. In the DC method the value of the series resistance and capacitance is determined based on the charging and discharging cycles. However, due to the very large capacitance of the supercapacitors and necessity of migration of ions to the whole area of the electrode, the test methods differs slightly from the DC methods used for conventional capacitors. The supercapacitors need a long time to reach an equilibrium state because some areas of the dielectric are very far and are very difficult to access for the ions. The test procedure for the DC method and structure of the measurement system are shown in Fig. 5 and Fig. 7 respectively. According to the diagram shown in Fig. 5, the supercapacitor in the first phase is charged with a constant current I_1 (CC first period) from the current source I_{S1} to a nominal voltage U_n . After that, the current and voltage sources are disconnected from the supercapacitor for the time t_S . Once the current and voltage sources are disconnected a small drop of the supercapacitor voltage takes place. In the first phase the drop

is caused by disappearance of the charging current whilst the self-discharge process is responsible for a very gentle drop of the voltage in the second phase. After time t_S , the constant voltage source CV is connected for 10-30 minutes and the voltage value is equal to the measured supercapacitor voltage after time t_S . The mentioned 10-30 minutes time is required to reach the equilibrium state. After this time, a process of discharging the capacitor with constant current I_2 by a current source I_{S2} is started (second CC period).

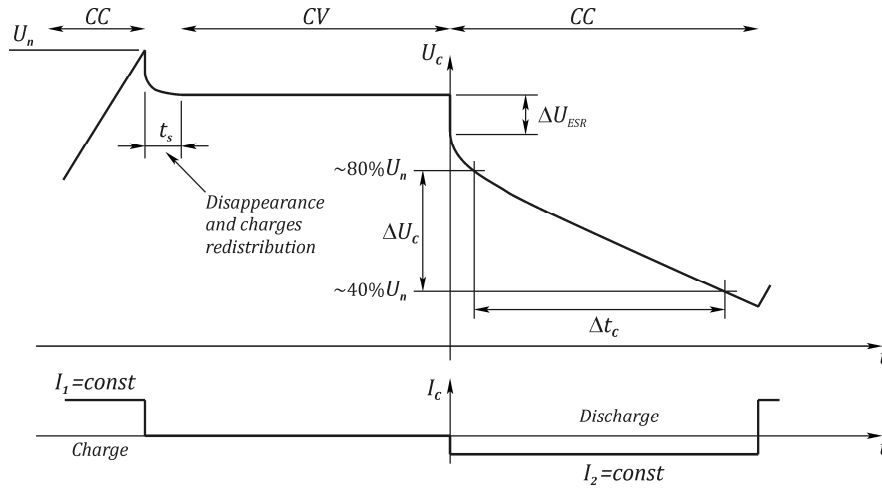

Fig. 5. The method of determination of the values of supercapacitor parameters with constant current CC and constant voltage CV .

The value of the equivalent series resistance can be determined as

$$ESR = \frac{\Delta U_{ESR}}{I_2}, \quad (1)$$

where ΔU_{ESR} is the voltage drop on the series resistance ESR due to I_2 current. The value of the equivalent capacitance can be derived as

$$C = \frac{\Delta Q_C}{\Delta U_C} = I_2 \frac{\Delta t_C}{\Delta U_C}, \quad (2)$$

where ΔU_C is the voltage drop during supercapacitor discharge from 80% U_n to 40% U_n and the Δt_C is the observation time.

In the AC method, the value of the supercapacitor impedance for a given frequency i.e. $f = 1$ kHz is determined. The values of equivalent supercapacitor parameters are determined based on its real and imaginary parts.

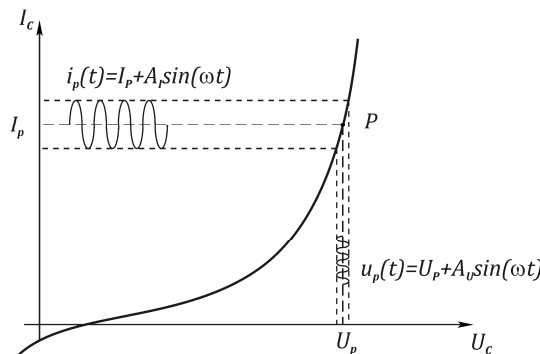

Fig. 6. The supercapacitor impedance characteristic obtained by the AC method.

The value of the capacitance C can be calculated as

$$C = -\frac{1}{2\pi \operatorname{Im}(Z)f}, \quad (3)$$

while the series resistance ESR can be determined as

$$ESR = \operatorname{Re}(Z), \quad (4)$$

where $\operatorname{Re}(Z)$ and $\operatorname{Im}(Z)$ are the real and imaginary parts of the supercapacitor complex impedance Z for a given frequency f respectively.

4.2. Test setup

Fig. 7 shows the scheme of the measurement system. There are two voltage-controlled current sources I_{S1} and I_{S2} , and one voltage source U_S . Current source I_{S1} is used to charge, while I_{S2} to discharge the supercapacitor. The current source intensities are measured through the voltage drop across the R_{I1} and R_{I2} resistors respectively. All sources are connected to the supercapacitor by relays. The R_U resistor limits the charge and discharge current of voltage source, while the R_{IC} allows to measure the supercapacitor current.

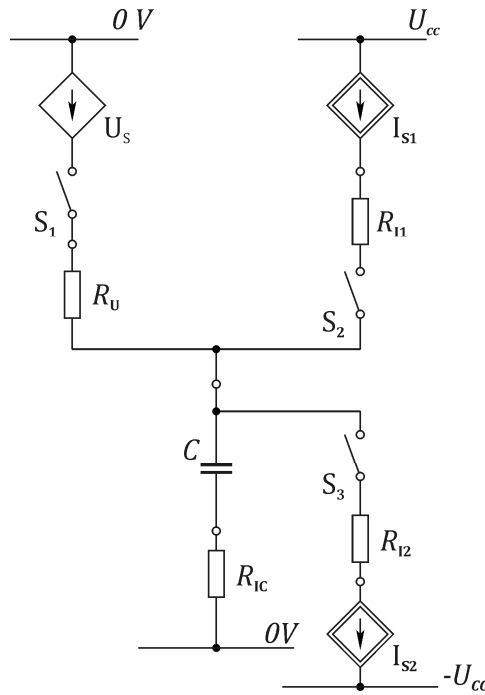

Fig. 7. Test setup to measure the values of supercapacitor equivalent parameters.

The whole measurement system is shown in Fig. 8. It comprised the test setup shown in Fig. 7 and universal I/O board - NI PCI 6259 which is built into a PC. Generated by analog outputs (AO) signals control the current and voltage sources. All voltages are measured through analog inputs (AI). A/D and D/A converters are of 16 bits resolution. The switches S_1 , S_2 and S_3 are controlled by the I/O board digital outputs (DO).

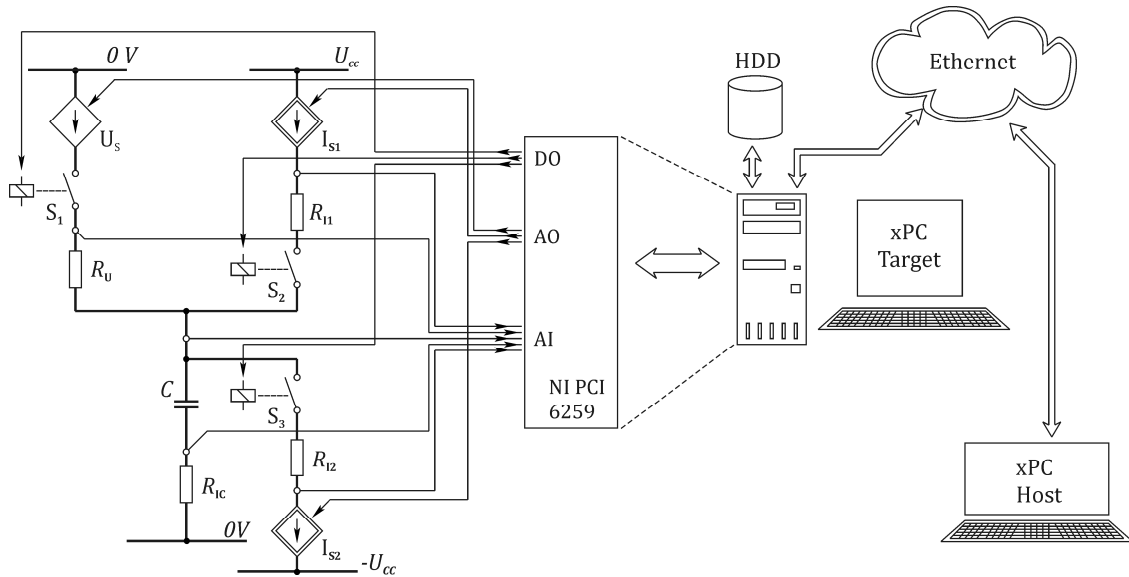

Fig. 8. Scheme of the measurement system to measure the values of supercapacitor equivalent parameters and to provide the degradation processes.

The measurement procedure is carried out in accordance with the algorithm prepared in Matlab. For this purpose the PC computer with Matlab is configured so that it would work in Matlab's *xPC* mode. The PC computer, equipped with a measurement card, works as *xPC Target*, while the second computer works as the *xPC Host*. The advantage of such a solution is a relatively high measurement speed. The *xPC Target* computer works on a special Matlab's operating system and can work with a time resolution up to 1 μ s. Although the changes in the DC mode are relatively slow, the high measurement speed is particularly important for the series resistance measurement. The high sampling rate allows determining more precisely the moment between the voltage drop across the series resistance and the start of the discharging process of the capacitor.

All signals are precisely generated based on the functional algorithm stored in a file on a hard drive, depending on the signal values or some other conditions, e.g. time. All measured values with time stamps are saved on hard drive on the *xPC Target* computer. All control signals and measurement data are exchanged between the *xPC Host* and *xPC Target* computer via an Ethernet card.

The values of equivalent series resistance and capacitance strongly depend on the temperature and for that reason the measurement system is equipped with a special temperature chamber [8]. It allows keeping the constant temperature of the supercapacitor in the range of +30° C to +80° C.

5. Measurement results

During the test procedure the capacitance C and the equivalent series resistance ESR were determined for three supercapacitors and one electrolytic capacitor. The C and ESR measurements were carried out using the AC and DC method. Furthermore the influence of temperature on the change in capacitance and the equivalent series resistance were also determined.

5.1. Measurement procedures for C and ESR

The values of the equivalent series resistance ESR and equivalent capacity C of three supercapacitors were determined, out of which one with a capacitance of 1 F and one of capacitance 0.22 F and nominal voltage 5.5 V and one of capacitance 100 F and 2.7 V.

To verify the test environment and the measurement procedure, the same parameters were determined for a 3300 μF and 40 V typical electrolytic capacitor. Figure 9 shows the current and voltage characteristic for the supercapacitor 1 F/5.5 V. One cycle consists of constant current CC charge, constant voltage CV and constant current CC discharge periods.

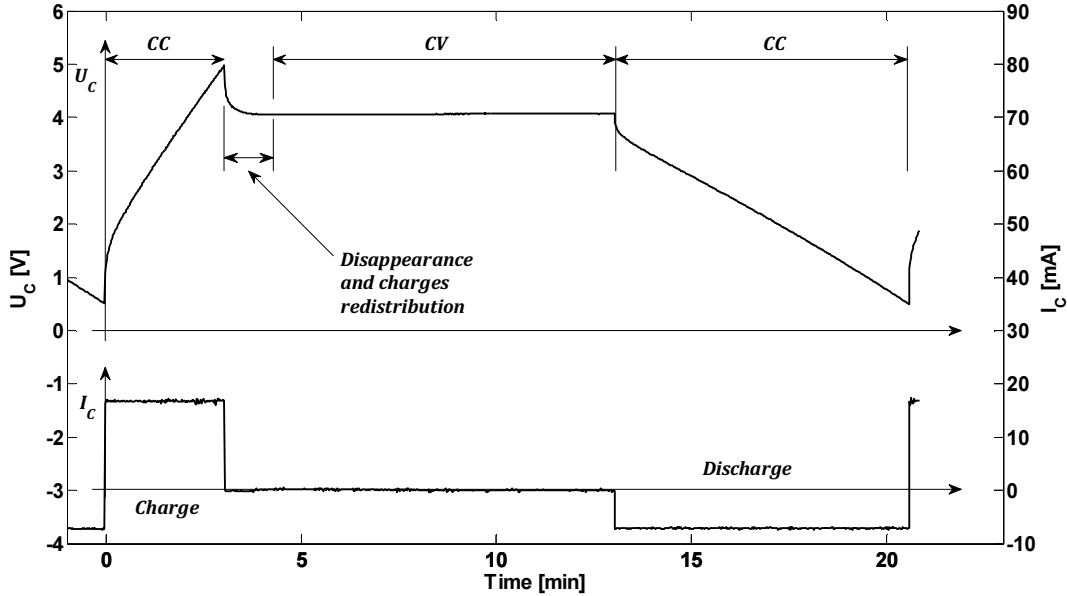

Fig. 9. The current and voltage curve during tests of a 1 F and 5.5 V nominal voltage supercapacitor.

Assuming the charge and discharge current to be equal $I_1 = 18 \text{ mA}$ and $I_2 = 8.4 \text{ mA}$ respectively, for 1 F capacity, the values of the equivalent supercapacitor parameters according to (1) and (2) equations can be calculated as

$$ESR = \frac{\Delta U}{I_2} - R_{IC} = \frac{0.1396 \text{ V}}{8.4 \text{ mA}} - 8.6 \Omega = 7.99 \Omega \quad (5)$$

and

$$C = \frac{\Delta Q_n}{\Delta U_n} = I_2 \frac{\Delta t_n}{\Delta U_n} = 8.4 \text{ mA} \times \frac{(400 - 50) \text{ sec}}{(3.78 - 0.98) \text{ V}} = 1.05 \text{ F} . \quad (6)$$

The measured parameters for all supercapacitors are shown in Table 1.

The proposed measurement system allows also to measurement of C and ESR using the AC method. The characteristics $I = f(U)$ determined during tests and the ESR value calculated according to the equation (4) is shown in Fig. 10. The tests were conducted for a frequency of $f = 1 \text{ kHz}$.

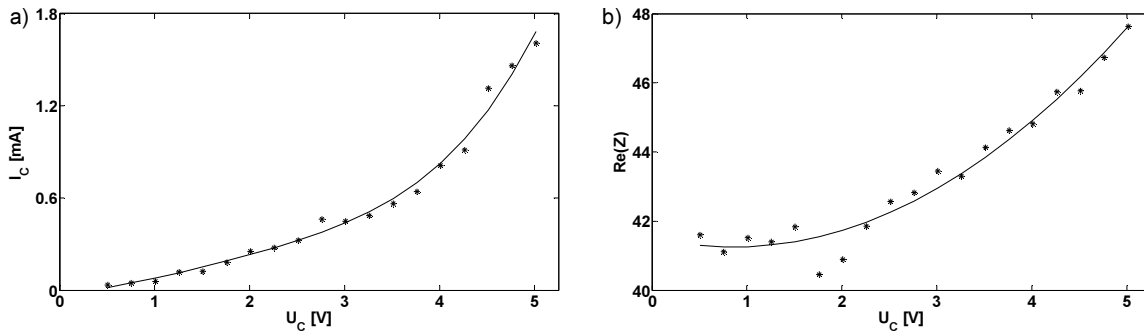

Fig. 10. The changes of current a) and equivalent series resistance b) as a function of operating point of a supercapacitor of 0.22 F capacity and 5.5 V nominal voltage obtained by the AC method at a frequency of 1 kHz.

In practice for the frequency above 10 Hz there is no phase shift between voltage and current of the capacitor and as a result for high frequencies only the value of the series resistance can be determined. The measurements for the electrolytic capacitor were carried out at a frequency of 100 Hz.

Table 1. Values of equivalent parameters measured for same capacitors.

No.	Type of capacitor	Nominal values			DC method		AC method		
		C	ESR	U_n	C	ESR	C	ESR	frequency
		[F]	[Ω]	[V]	[F]	[Ω]	[F]	[Ω]	[kHz]
1	Supercapacitor 1	0.22	≤ 75	5.5	0.194	38.7	-	37.8	1
2	Supercapacitor 2	1	≤ 30	5.5	1.050	7.99	-	7.14	1
3	Supercapacitor 3	100	0.01	2.7	82.60	0.3	-	0.041	1
4	Typical electrolytic capacitor	0.0033	0.067	40	0.0046	1.2	-	0.11	0.1

5.2. The temperature effect

The influence of temperature on the change in capacitance and the equivalent series resistance was also determined. The measurements were carried out according to the test set-up shown in Fig. 11. The temperature was controlled by a PLC controller.

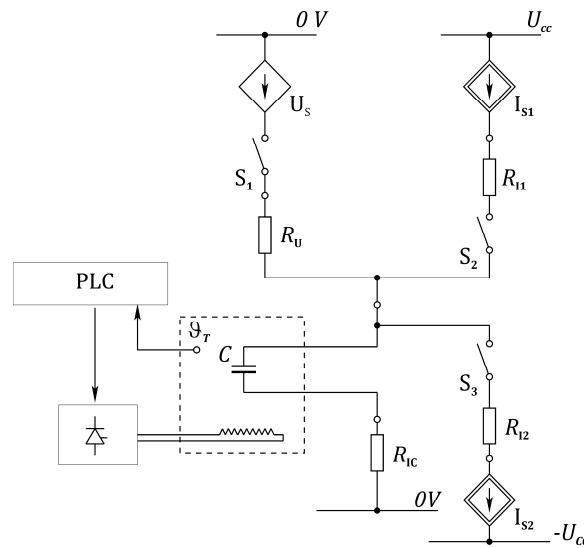

Fig. 11. Test setup to measure the influence of temperature changes on supercapacitor equivalent circuit parameters.

The supercapacitors were put into a temperature chamber. The temperature was then being changed beginning from the ambient temperature up to $+50^\circ\text{C}$ in 10°C steps. The results of percentage changes of the value of capacitance and resistance to the nominal values specified at ambient temperature are shown in Fig. 12 a) and b), respectively. As one can see, the supercapacitor of lower capacitance was less sensitive to the capacitance changes in response to the temperature change. Similarly, the equivalent series resistance changes were noticeably greater for supercapacitors having greater ERS. The equivalent series resistance of 100 F supercapacitor changed about 15% while ESR of 1 F and 0.22 F supercapacitors changed by 45% and 25%, respectively.

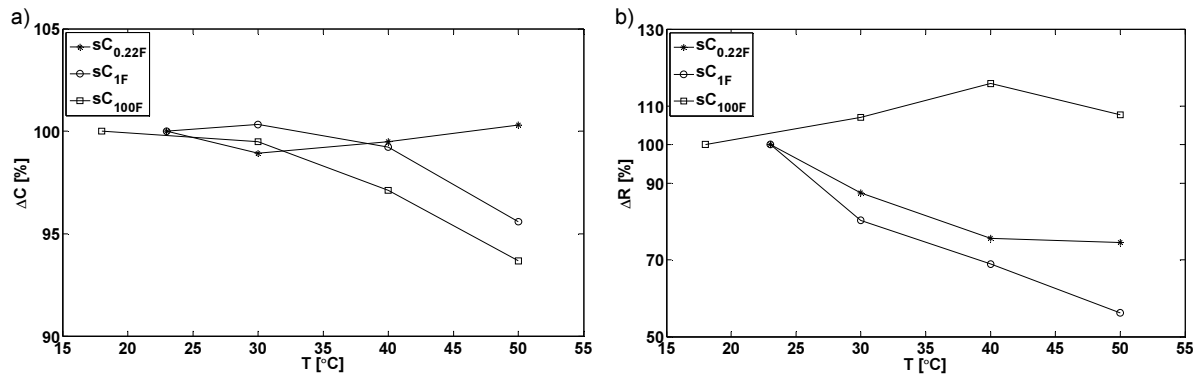

Fig. 12. The percentage changes of capacities a) and equivalent series resistance b) as a function of temperature.

6. Conclusions

Some specific properties of the supercapacitors and higher reliability requirements resulted in using more and more sophisticated measurement methods and procedures in order to assess their technical state. The developed measuring system allows the measurement procedure to be carried out fully automatically and in accordance with specified requirements. This allows shortening its duration whilst guaranteeing a very high accuracy at the same time.

The described system is used not only to determine the equivalent parameters of the supercapacitors, but also to observe how they change in time. Additionally, using the accelerated ageing tests, various effects of degradation parameters, such as temperature, operating voltage and number of charge/discharge cycles to their changes can be determined faster. Furthermore, the measurement system can easily be adopted to assess the state of the supercapacitor online, during their operation. It can also be used to control the changes of capacitance and equivalent series resistance and signal when the limit values are reached. In this way it allows to replace a faulty device in advance thus preventing the whole system from damage.

References

- [1] Jayalakshmi, M., Balasubramanian, K. (2008). Simple Capacitors to Supercapacitors - An Overview, *Int. J. Electrochem. Sci.* 3, 1196–1217.
- [2] Mallika, S., Kumar, R. S. (2011). Review on Ultracapacitor- Battery Interface for Energy Management System, *International Journal of Engineering and Technology* Vol.3 (1), 37–43.
- [3] Oukaour, A., Tala-Ighil, B., Al Sakka, M., Gualous, H., Gallay, R., Boudart, B. (2013). Calendar ageing and health diagnosis of supercapacitor. *Electric Power Systems Research* 95, 330–338.
- [4] Pandolfo, A. G., Hollenkamp, A. F. (2006). Carbon properties and their role in supercapacitors, *Journal of Power Sources* 157, 11–27.
- [5] Chunsheng, D., Ning, P. (2006). High power density supercapacitor electrodes of carbon nanotube films by electrophoretic deposition, *Nanotechnology* 17, 5314–5318.
- [6] Yuege, Z., Xuerong, Y., Guofu, Z. (2011). Degradation Model and Maintenance Strategy of the Electrolytic Capacitors for Electronics Applications, *Prognostics & System Health Management Conference (PHM2011 Shenzhen)*.
- [7] Gualous, H., Gallay, R., Al Sakka, M., Oukaour, A., Tala-Ighil, B., Boudart, B. (2012). Calendar and cycling ageing of activated carbon supercapacitor for automotive application, *Microelectronics Reliability* 52, 2477–2481.
- [8] Kötz, R., Hahn, M., Gallay, R. (2006). Temperature behavior and impedance fundamentals of supercapacitors, *Journal of Power Sources* Vol. 154, Issue 2, 550–555.